

G

## 6657 Colorado Blvd, Unit E, Commerce City, CO

Warehouse Space for Lease

### FOR LEASE

#### PROPERTY HIGHLIGHTS

- Clear Span Warehouse
- Drive-thru Loading
- Sprinkler System



SPACE AVAILABLE:  
3,000 SF

LEASE PRICE:  
\$4,100/MONTH

For More Information, Contact:

**Russell Gruber** | *Industrial Specialist/Owner*  
(720) 490-1442  
russell@grubercre.com

**Steve Fletcher** | *Industrial Specialist*  
(720) 320-0366  
steve@grubercre.com

## PROPERTY DETAILS

- **Space Available:** 3,000 SF
- **Office Space:** 485 SF
- **Ceiling Height:** 18'ft
- **Zoning:** I-2 (Commerce City)
- **Loading:** Two (2) Grade Level Doors (12'x14')

## FLOOR PLAN

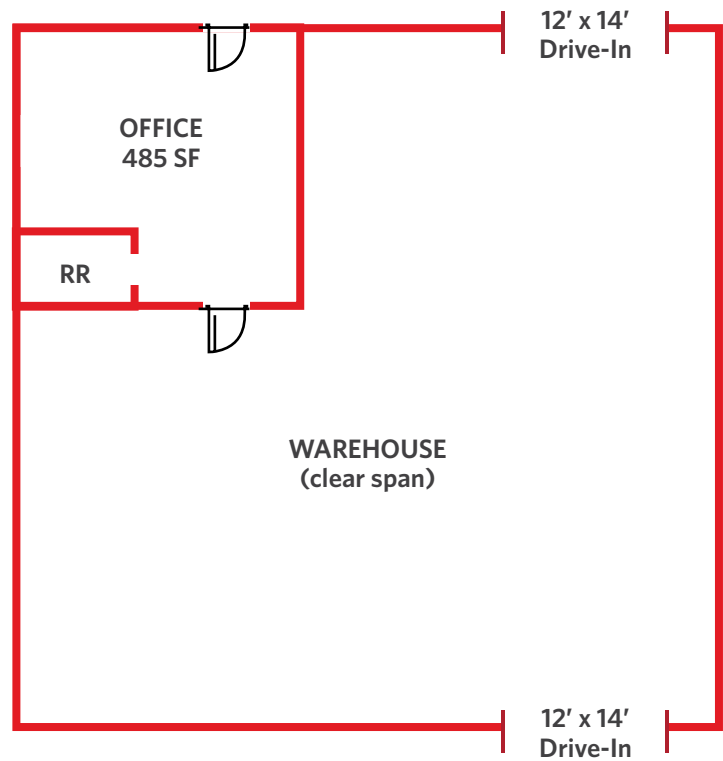

## AERIAL



### For More Information, Contact:

**Russell Gruber** | *Industrial Specialist/Owner*  
(720) 490-1442  
russell@grubercre.com

**Steve Fletcher** | *Industrial Specialist*  
(720) 320-0366  
steve@grubercre.com

